

Transient Voltage Suppressors (TVS) Data Sheet

Features

- For surface mounted applications in order to optimize board space
- Low profile package
- Built-in strain relief
- Glass passivated junction
- Low inductance
- Excellent clamping capability
- 6600W peak pulse power capability at 10/1000μs waveform, repetition rate (duty cycle): 0.01%
- Fast response time
- Typical I_R less than 2μA above 22V
- High Temperature soldering: 260°C/10 seconds at terminals
- Plastic package has underwriters laboratory flammability 94V-0
- Meets MSL level 1, per J-STD-020
- AEC-Q101 qualified (Automotive grade with suffix "Q".)
- Expsemi electronics
- UL Certification:E492977



Mechanical Data

- Case: JEDEC DO-214AB. Molded plastic over glass passivated junction
- Terminal: Solder plated, solderable per MIL-STD-750, Method 2026
- Polarity: Color band denotes cathode except bi-directional models

Applications

- AC/DC power supply
- I/O interface
- Low frequency signal transmission line

Maximum Ratings and Characteristics

Ratings at 25°C ambient temperature unless otherwise specified.

Rating	Symbol	Value	Units
Peak pulse power dissipation at 10/1000μs waveform (Note1, Note2, Fig.1)	P_{PPM}	Minimum	6600Watts
Peak pulse current of at 10/1000μs waveform (Note 1, Fig.3)	I_{PPM}	See Table	Amps
Steady state power dissipation at $T_A=50^\circ\text{C}$ (Fig.5)	$P_{M(AV)}$	6.5	Watts
Peak forward surge current, 8.3ms single half sine-wave superimposed on rated load, (JEDEC Method) (Note3, Fig.6)	I_{FSM}	300	Amps
Operating junction and Storage Temperature Range.	T_J, T_{STG}	-65 to +150	°C
Typical thermal resistance junction to lead	$R_{\theta JL}$	15	°C/W
Typical thermal resistance junction to ambient	$R_{\theta JA}$	75	°C/W

Notes: 1. Non-repetitive current pulse, per Fig.3 and derated above $T_A=25^\circ\text{C}$ per Fig.2.

2. Mounted on 8.0mm×8.0mm copper pads to each terminal.

3. 8.3ms single half sine-wave, or equivalent square wave, duty cycle=4 pulses per minutes maximum.

Electrical Characteristics (T_A=25°C)

Part Number		Device Marking Code		Reverse Stand-Off Voltage	Breakdown Voltage @I _T	Test Current	Maximum Clamping Voltage @I _{PP}	Peak Pulse Current	Reverse Leakage @V _{RWM}
Unidirectional	Bidirectional	UNI	BI	V _{RWM} (V)	V _{BR} (V)	I _T (mA)	V _C (V)	I _{PP} (A)	I _R (μA)
6.6SMDJ11A	6.6SMDJ11CA	6PEN	6BEN	11.0	12.20~13.50	10	18.2	363	800
6.6SMDJ12A	6.6SMDJ12CA	6PEP	6BEP	12.0	13.30~14.70	10	19.9	332	800
6.6SMDJ13A	6.6SMDJ13CA	6PEQ	6BEQ	13.0	14.40~15.90	10	21.5	307	500
6.6SMDJ14A	6.6SMDJ14CA	6PER	6BER	14.0	15.60~17.20	10	23.2	284	200
6.6SMDJ15A	6.6SMDJ15CA	6PES	6BES	15.0	16.70~18.50	1	24.4	270	100
6.6SMDJ16A	6.6SMDJ16CA	6PET	6BET	16.0	17.80~19.70	1	26.0	254	50
6.6SMDJ17A	6.6SMDJ17CA	6PEU	6BEU	17.0	18.90~20.90	1	27.6	239	20
6.6SMDJ18A	6.6SMDJ18CA	6PEV	6BEV	18.0	20.00~22.10	1	29.2	226	10
6.6SMDJ20A	6.6SMDJ20CA	6PEW	6BEW	20.0	22.20~24.50	1	32.4	204	5
6.6SMDJ22A	6.6SMDJ22CA	6PEX	6BEX	22.0	24.40~26.90	1	35.5	186	5
6.6SMDJ24A	6.6SMDJ24CA	6PEZ	6BEZ	24.0	26.70~29.50	1	38.9	170	2
6.6SMDJ26A	6.6SMDJ26CA	6PFE	6BFE	26.0	28.90~31.90	1	42.1	157	2
6.6SMDJ28A	6.6SMDJ28CA	6PFG	6BFG	28.0	31.10~34.40	1	45.4	145	2
6.6SMDJ30A	6.6SMDJ30CA	6PFK	6BFK	30.0	33.30~36.80	1	48.4	136	2
6.6SMDJ33A	6.6SMDJ33CA	6PFM	6BFM	33.0	36.70~40.60	1	53.3	124	2
6.6SMDJ36A	6.6SMDJ36CA	6PFP	6BFP	36.0	40.00~44.20	1	58.1	114	2
6.6SMDJ40A	6.6SMDJ40CA	6PFR	6BFR	40.0	44.40~49.10	1	64.5	102	2
6.6SMDJ43A	6.6SMDJ43CA	6PFT	6BFT	43.0	47.80~52.80	1	69.4	95.1	2
6.6SMDJ45A	6.6SMDJ45CA	6PFV	6BFV	45.0	50.00~55.30	1	72.7	90.7	2
6.6SMDJ48A	6.6SMDJ48CA	6PFX	6BFX	48.0	53.30~58.90	1	77.4	85.2	2
6.6SMDJ51A	6.6SMDJ51CA	6PFZ	6BFZ	51.0	56.70~62.70	1	82.4	80.1	2
6.6SMDJ54A	6.6SMDJ54CA	6PGE	6BGE	54.0	60.00~66.30	1	87.1	75.7	2
6.6SMDJ58A	6.6SMDJ58CA	6PGG	6BGG	58.0	64.40~71.20	1	93.6	70.5	2
6.6SMDJ60A	6.6SMDJ60CA	6PGK	6BGK	60.0	66.70~73.70	1	96.8	68.1	2

Ratings and Characteristic Curves ($T_A=25^\circ\text{C}$ unless otherwise noted)

Figure 1. Peak Pulse Power Rating Curve

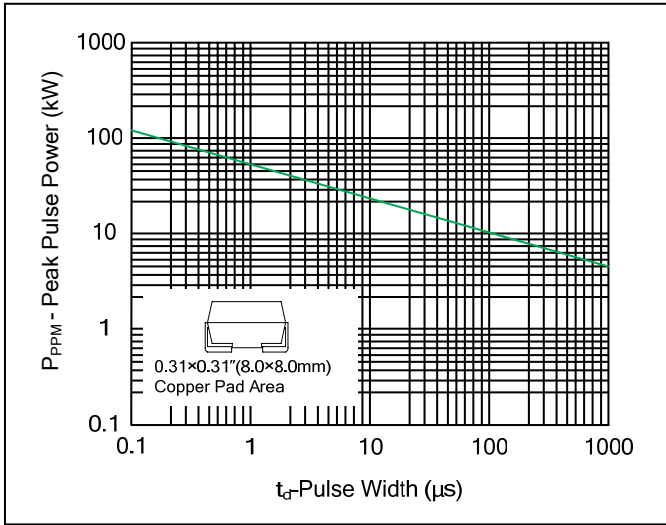

Figure 2. Pulse Derating Curve

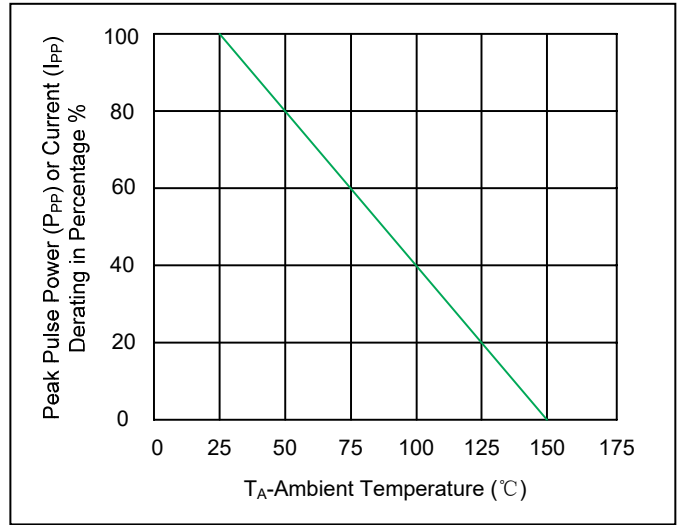

Figure 3. Pulse Waveform

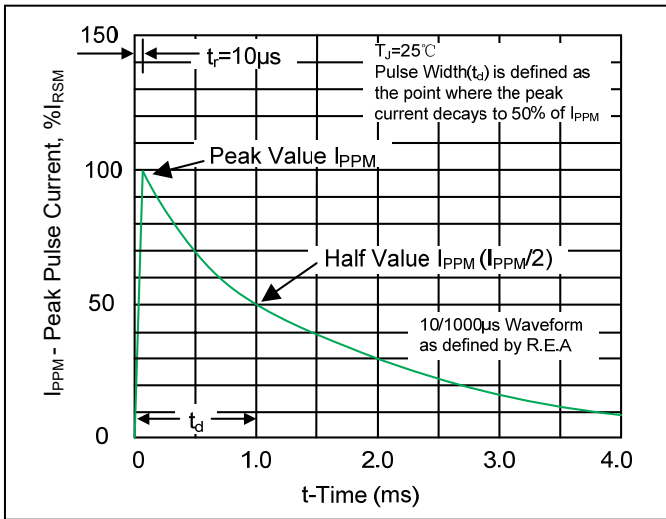

Figure 4. Typical Junction Capacitance

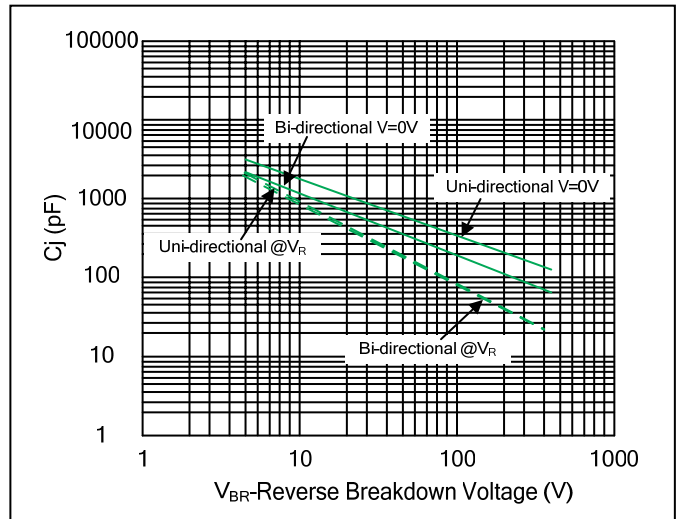

Figure 5. Steady State Power Dissipation Derating Curve

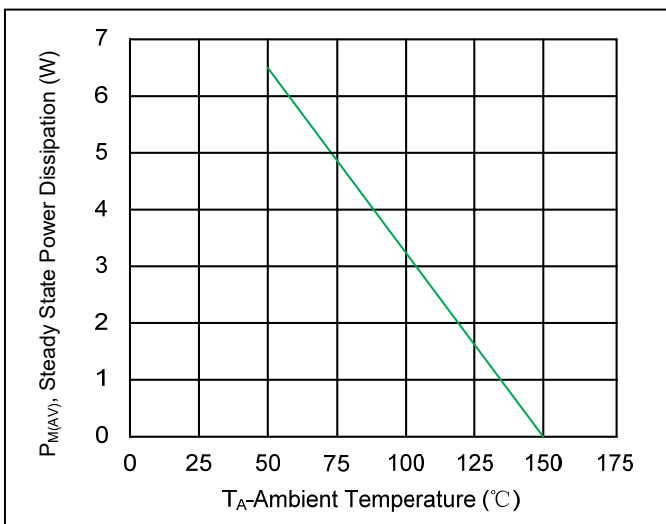
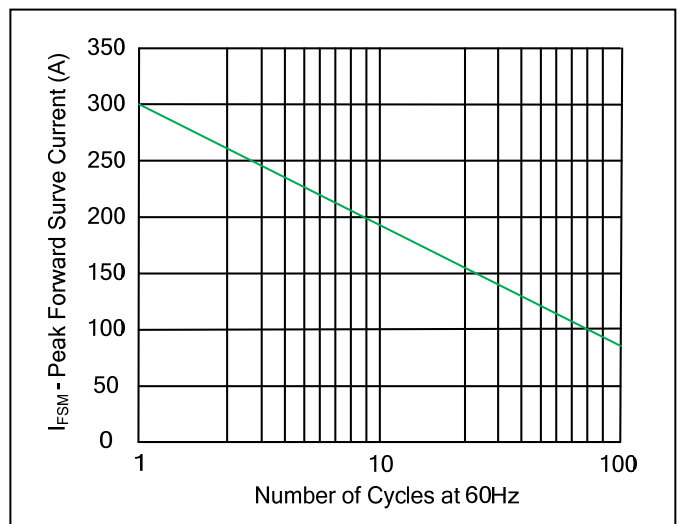

Figure 6. Maximum Non-Repetitive Forward Surge Current Uni-Directional Only



Recommended Soldering Conditions

Soldering Parameters

Reflow Condition		Lead-free assembly
Pre Heat	- Temperature Min ($T_{s(min)}$)	150°C
	- Temperature Max ($T_{s(max)}$)	200°C
	- Time (min to max) (t_s)	60 – 180 secs
Average ramp up rate (Liquidus Temp (T_A) to peak)		3°C/second max
$T_{s(max)}$ to T_A - Ramp-up Rate		3°C/second max
Reflow	- Temperature (T_A) (Liquidus)	217°C
	- Time (min to max) (t_s)	60 – 150 seconds
Peak Temperature (T_p)		260 ^{+0/-5} °C
Time within 5°C of actual peak Temperature (t_p)		20 – 40 seconds
Ramp-down Rate		6°C/second max
Time 25°C to peak Temperature (T_p)		8 minutes Max.
Do not exceed		260°C

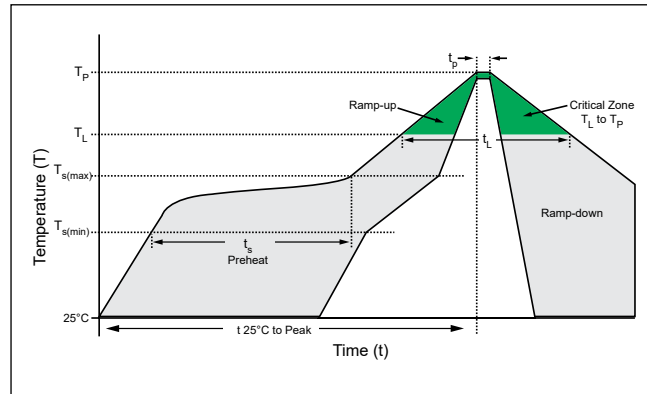

Physical Specifications

Case	JEDEC DO214AB. Molded plastic body over glass passivated junction
Polarity	Color band denotes positive end (cathode) except Bidirectional.
Terminal	Matte Tin-plated leads, Solderable per JESD22-B102

Environmental Specifications

High Temp. Storage	JESD22-A103
HTRB	JESD22-A108
Temperature Cycling	JESD22-A104
MSL	JEDEC-J-STD-020, Level 1
H3TRB	JESD22-A101
RSH	JESD22-A111

Dimensions

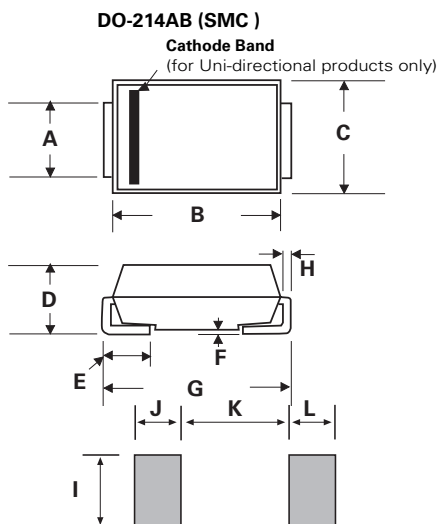

Dimensions	Inches		Millimeters	
	Min	Max	Min	Max
A	0.108	0.128	2.750	3.250
B	0.260	0.291	6.600	7.400
C	0.220	0.246	5.590	6.250
D	0.078	0.108	1.980	2.750
E	0.030	0.060	0.760	1.520
F	0.002	0.008	0.051	0.203
G	0.303	0.323	7.700	8.200
H	0.006	0.012	0.152	0.305
I	0.129	-	3.300	-
J	0.094	-	2.400	-
K	-	0.165	-	4.200
L	0.094	-	2.400	-

Part Numbering System

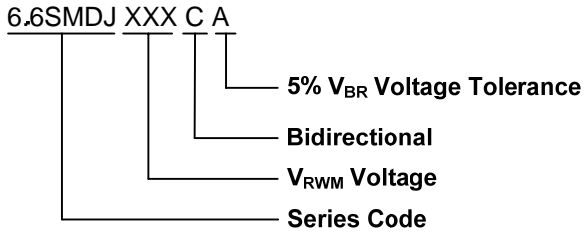

Part Marking System

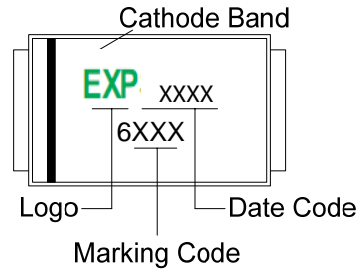

Packaging

Part number	Component Package	Quantity	Packaging Option	Packaging Specification
6.6SMDJxxxXX	DO-214AB	3000	Tape & Reel - 16mm tape/13" reel	EIA STD RS-481

Tape and Reel Specification

